

Split Core Hall Effect AC/DC Current Sensor CYHCS-EKFSC

This Hall Effect current sensor is based on open loop principle and designed with a split core and high galvanic isolation between primary conductor and secondary circuit. It can be used for measurement of AC/DC current etc. The output of the transducer reflects the real wave of the current carrying conductor.

Product Characteristics	Applications
<ul style="list-style-type: none"> • Excellent accuracy • Very good linearity • Less power consumption • Split core window structure • Electrically isolating the output of the transducer from the current carrying conductor • No insertion loss • Current overload capability 	<ul style="list-style-type: none"> • Photovoltaic equipment • Frequency conversion timing equipment • Various power supplies • Uninterruptible power supplies (UPS) • Electric welding machines • Electrolyzing and electroplating equipment • Electric powered locomotive • Electric power network monitoring

Electrical Data

Primary Nominal Current I_r (A)	Measuring Range I_p (A)	Output Current I_o (mA)	Window Size (mm)	Part number
300A	0 ~ ± 300A	X=2: 0±20mA X=5: 4-20mA	Ø62	CYHCS-EKFSC-300A-X
400A	0 ~ ± 400A			CYHCS-EKFSC-400A-X
500A	0 ~ ± 500A			CYHCS-EKFSC-500A-X
800A	0 ~ ± 800A			CYHCS-EKFSC-800A-X
1000A	0 ~ ± 1000A			CYHCS-EKFSC-1000A-X
2000A	0 ~ ± 2000A			CYHCS-EKFSC-2000A-X
4000A	0 ~ ± 4000A			CYHCS-EKFSC-4000A-X
5000A	0 ~ ± 5000A			CYHCS-EKFSC-5000A-X
6000A	0 ~ ± 6000A			CYHCS-EKFSC-6000A-X

Supply Voltage:	$V_{cc}=24VDC \pm 5\%$
Current Consumption:	$I_c < 35mA + I_o$
Isolation Voltage:	5kV, 50/60Hz, 1min
Measuring resistance:	$R_m \leq 600\Omega$
Accuracy at I_r , $T_A=25^\circ C$ (without offset):	$E < \pm 1.0\% FS$
Linearity from 0 to I_r , $T_A=25^\circ C$:	$E_L < \pm 1.0\% FS$
Overload capability:	3 times of primary nominal current
Electric Offset Current, $T_A=25^\circ C$:	$I_{oe} = 4mA$ or $12mA$ for $I_o=4-20mA$, $I_{oe} \leq \pm 0.1mA$ for $I_o=0\pm 20mA$
Magnetic Offset Current ($I_r \rightarrow 0$):	$I_{om} \leq \pm 0.1mA$
Thermal Drift of Offset Current ($I_p=0$, $T_A=-25^\circ C \sim 85^\circ C$):	$I_{ot} \leq \pm 200ppm/^\circ C$
Response Time at 90% of I_p ($f=1k Hz$):	$t_r \leq 7\mu s$
Frequency Bandwidth (-3dB):	$f_b = DC - 20kHz$

General Data

Ambient Operating Temperature:	$T_A = -25^\circ C \sim +85^\circ C$
Ambient Storage Temperature:	$T_S = -40^\circ C \sim +100^\circ C$
Unit Weight:	500g/pc
Standard:	Q/320115QHKJ01-2016

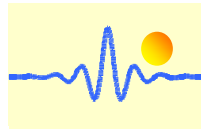

PIN Definition and Dimensions

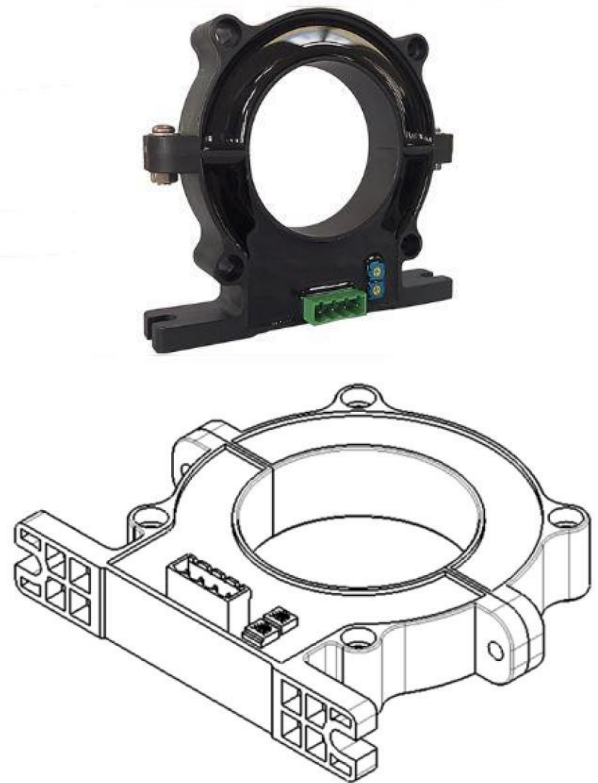
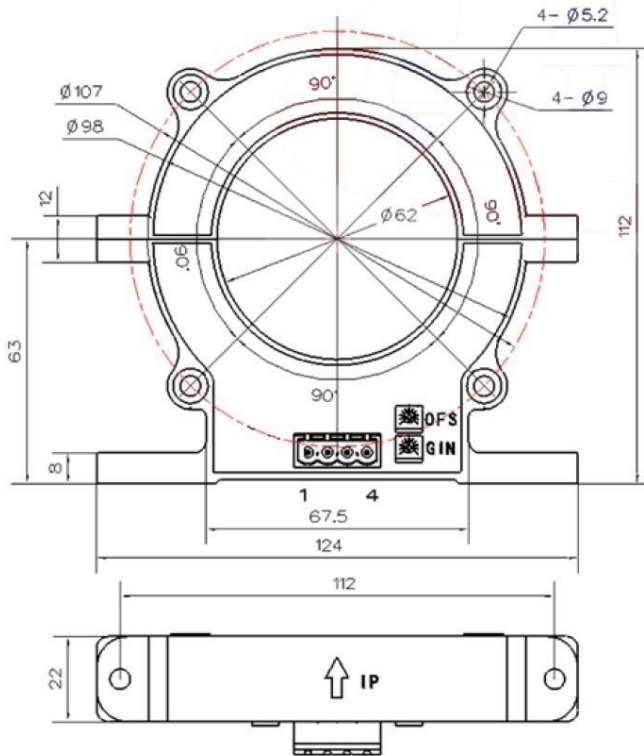

OFS: Offset Adjustment

GIN: Gain Adjustment

Pin arrangement of connector:

1:	Vcc	2:	GND
3:	OUTPUT	4:	GND

Cable connection:

Red:	Vcc
Blue:	GND
Yellow:	OUTPUT
Black:	GND

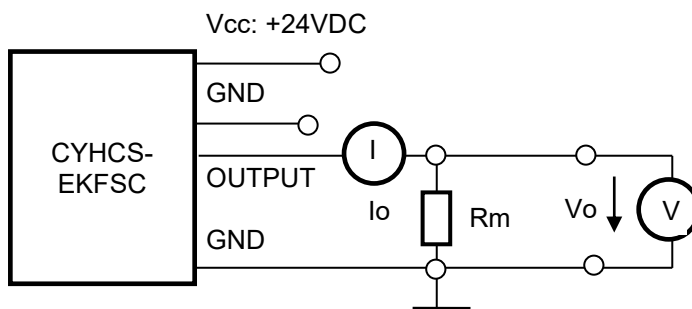

$$R_m \leq 600\Omega$$

Notes:

1. Connect the terminals of power source, output respectively and correctly, never make wrong connection.
2. Two potentiometers can be adjusted, only, if necessary, by turning slowly to the required accuracy with a small screwdriver.
3. The best accuracy can be achieved when the primary input current conductor is positioned at the center of sensor window and occupies over 50% of the window area.
4. The in-phase output can be obtained when the current direction of current carrying conductor is the same as the direction of arrow marked on the transducer