

Hall Effect DC Current Sensor CYHCT-FAV

This Hall Effect current sensor is based on open loop principle and designed with a high galvanic isolation between primary conductor and secondary circuit. It can be used for measurement of DC current, DC pulse currents etc. The output of the transducer reflects the real wave of the current carrying conductor.

Product Characteristics	Applications
<ul style="list-style-type: none"> • Excellent accuracy • Very good linearity • Less power consumption • Window structure • Electrically isolating the output of the transducer from the current carrying conductor • No insertion loss • Current overload capability 	<ul style="list-style-type: none"> • Photovoltaic equipment • Frequency conversion timing equipment • Various power supply • Uninterruptible power supplies (UPS) • Electric welding machines • Transformer substation • Numerical controlled machine tools • Electric powered locomotive • Microcomputer monitoring • Electric power network monitoring

Electrical Data

Primary Nominal DC Current I_r (A)	Measuring Range (A)	DC Output Voltage (V)	Window Size (mm)	Part number (see application notes on page 3)
300	0~±300	x=0: 0-4V ±1.0% x=3: 0-5V ±1.0% x=8: 0-10V ±1.0%	51x13	CYHCT-FAV-U/B300A-xn
400	0~±400			CYHCT-FAV-U/B400A-xn
500	0~±500			CYHCT-FAV-U/B500A-xn
600	0~±600			CYHCT-FAV-U/B600A-xn
800	0~±800			CYHCT-FAV-U/B800A-xn
1000	0~±1000			CYHCT-FAV-U/B1000A-xn
1500	0~±1500			CYHCT-FAV-U/B1500A-xn
2000	0~±2000			CYHCT-FAV-U/B2000A-xn

(n=2, V_{cc} = +12VDC; n=3, V_{cc} =+15VDC; n=4, V_{cc} =+24VDC U: unidirectional input current; B: bidirectional input current, please give U or B in Part number)

Supply Voltage	V_{cc} = +12V, +15V, +24VDC ± 5%
Output Voltage at I_r , $T_A=25^\circ\text{C}$:	V_{out} = 0- 4V, 0-5V, 0-10VDC
Current Consumption	I_c < 25mA
Galvanic isolation, 50/60Hz, 1min:	3kV rms
Output Impedance:	R_{out} < 150Ω
Load resistance:	10kΩ

Accuracy and Dynamic performance data

Accuracy at I_r , $T_A=25^\circ\text{C}$,	X < ±1.0% FS
Linearity from 0 to I_r , $T_A=25^\circ\text{C}$,	E_L < ±0.5% FS
Electric Offset Voltage, $T_A=25^\circ\text{C}$,	V_{oe} < 50mV
Magnetic Offset Voltage ($I_r \rightarrow 0$)	V_{om} < ±20mV
Thermal Drift of Offset Voltage,	V_{ot} < ±1.0mV/°C
Response Time at 90% of I_P ($f=1\text{kHz}$)	t_r < 1ms
Frequency Bandwidth (-3dB),	f_b = DC - 20 kHz
Case Material:	PBT heat resistant 125°C, flame retardant

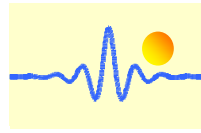

General Data

Ambient Operating Temperature,
Ambient Storage Temperature,
Unit weight:

$T_A = -25^{\circ}\text{C} \sim +85^{\circ}\text{C}$
 $T_S = -40^{\circ}\text{C} \sim +100^{\circ}\text{C}$
300g/unit

Dimensions

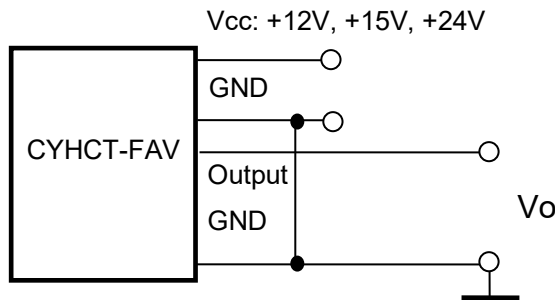
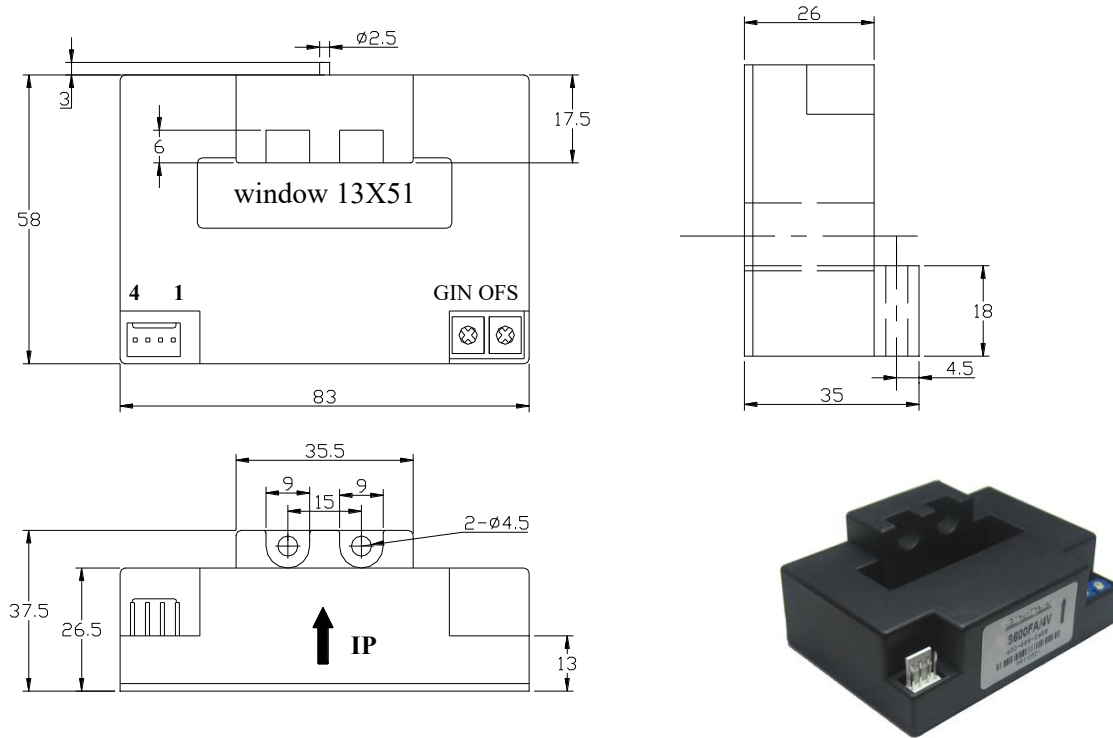

Pin Arrangement

- 1: Vcc
- 2: Ground
- 3: Output
- 4: Ground

GIN: gain adjustment
OFS: offset adjustment

Notes:

1. Connect the terminals of power source, output respectively and correctly, never make wrong connection.
2. Two potentiometers can be adjusted, only if necessary, by turning slowly to the required accuracy with a small screwdriver.
3. The best accuracy can be achieved when the window is fully filled with bus-bar (current carrying conductor).
4. The in-phase output can be obtained when the direction of current of current carrying conductor is the same as the direction of arrow marked on the transducer

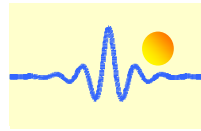

Application Notes

1) Part number CYHCT-FAV-U/BxxxxA-xn

U: unidirectional input current; **B:** bidirectional input current; **xxxx:** current value; **x:** output voltage (**x=0:** 0-4V $\pm 1.0\%$; **x=3:** 0-5V $\pm 1.0\%$; **x=8:** 0-10V $\pm 1.0\%$); **n:** power supply (**n=2,** $V_{cc} = +12VDC$; **n=3,** $V_{cc} = +15VDC$; **n=4,** $V_{cc} = +24VDC$)

Example 1: CYHCT-FAV-U1000A-32 Hall Effect DC Current sensor with
Output signal: 0 – 5V DC
Power supply: +12V DC
Rated input current: 0 - 1000A DC (unidirectional)

Example 2: CYHCT-FAV-B1000A-84 Hall Effect DC Current sensor with
Output signal: 0 – 10V DC
Power supply: +24V DC
Rated input current: -1000A - 0 - +1000A DC (bidirectional)

2) Relation between Input current and output signal

Current Sensor CYHCT-FAV-U1000A-32	
Input current (A)	Output voltage V_o (V)
0	0
250	1.25
500	2.5
750	3.75
1000	5

Current Sensor CYHCT-FAV-B1000A-84	
Input current (A)	Output voltage V_o (V)
-1000	0
-750	1.25
-500	2.5
-250	3.75
0	5
250	6.25
500	7.5
750	8.75
1000	10