

DC Current Sensor CYCT03-xnWS3

The **CYCT03-xnWS3** DC current sensor/transducer works according to Magnetic Modulation and is designed for applications to measurement and monitoring of DC current. The output signal (DC voltage or current) of this transducer is proportional to the input DC current.

Features and Advantages	Applications
<ul style="list-style-type: none"> DC current measurement High isolation between primary and secondary circuits Protection against reversed polarity Output protection against electrical disturbances 	<ul style="list-style-type: none"> DC motor drivers Battery banks, such as, monitoring load current and charge current, verifying operation Power supply management Telecommunication application

Specifications

Rated input current range	5mA, 10mA, 20mA, 50mA, 100mA, 200mA, 500mA, 750mA, 1A, 2A, 3A, 5A, 10A, 15A, 20A, 25A
Output signal	0-5VDC, 0-20 mA, 4-20 mA, 0-10V DC
Power supply	+12VDC, +15VDC, +24VDC
Measuring accuracy	±1.0% FS
Linearity (10% - 100%), 25°C	±0.5% FS
Isolation	between input, output and power supply
Load resistance	≥2kΩ for voltage output, ≤250Ω for current output
Isolation withstanding voltage	2.5 kV DC, 1min, leakage current 1mA
Operating temperature	-40°C ~ +85°C
Storage temperature	-40°C ~ +85°C
Relative humidity	10% ~ 90%
Response time	≤120ms
Thermal drift of offset voltage	≤600ppm/°C
Thermal Drift (-40°C to 85°C)	<2200ppm /°C
Quiescent power consumption	500mW – 1300mW (depending on power supply)
Mounting	DIN rail
Case style	WS3 with aperture Ø20mm

Definition of Part number:

CYCT03	-	x	n	WS3	-	1.0	-	M
(1)		(2)	(3)	(4)		(5)		(6)

(1)	(2)	(3)	(4)	(5)	(6)
Series name	Output signal	Power supply	Case style	Accuracy class	Input current range (M=U/B+m)
CYCT03	x=3: 0-5V DC x=4: 0-20mA DC x=5: 4-20mA DC x=8: 0-10V DC	n=2: +12V DC n=3: +15V DC n=4: +24V DC	WS3	1.0%	m=5mA ~ 500mA, 750mA, 1A, 2A, 3A, 5A, 10A, 15A, 20A, 25A

U: uni-directional input current; **B:** bi-directional input current

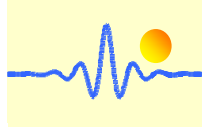

Example 1: CYCT03-32WS3-1.0-U10mA, DC Current sensor with
Output signal: 0-5V DC
Power supply: +12V DC
Rated input current: 0-10mA DC (uni-directional)

Example 2: CYCT03-54WS3-1.0-B10A, DC Current sensor with
Output signal: 4-20mA DC (12mA±8mA)
Power supply: +24V DC
Rated input current: -10A ~ 0A ~ +10ADC (bi-directional)

DIMENSIONS (mm)

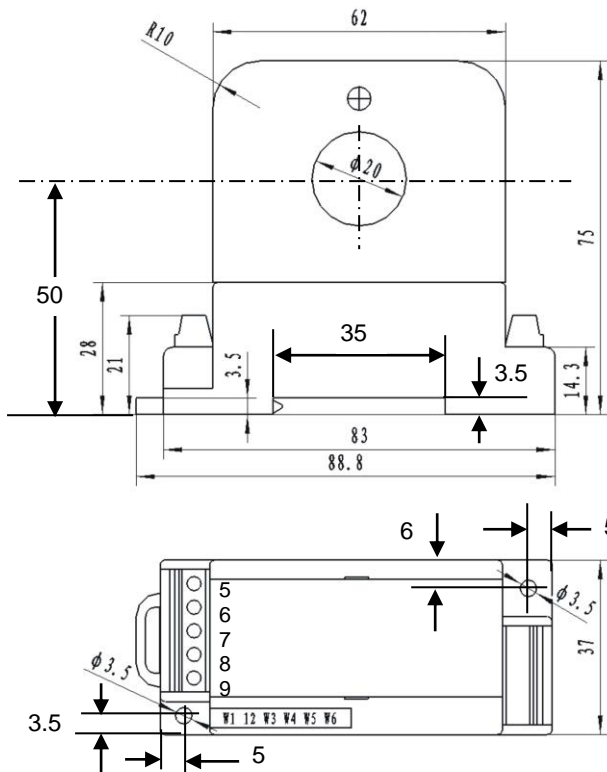

Dimensions: 75mm x 83mm x 37mm, Aperture: Ø20 mm

CONNECTIONS

Wiring of Terminals for voltage output:

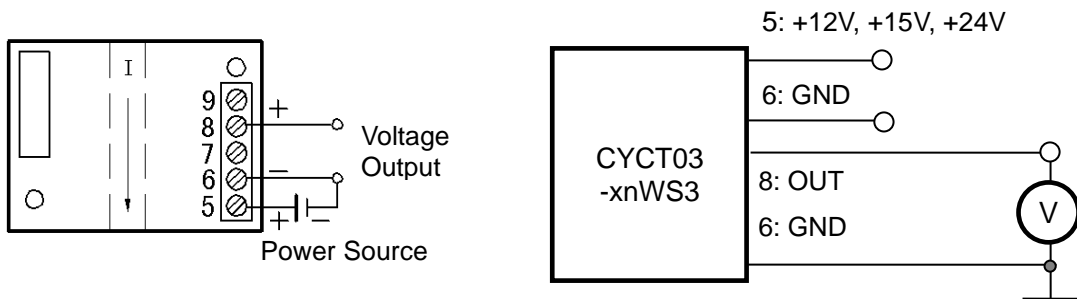

5: +12V, +15V, +24V Power Supply

6: GND

8: Voltage output

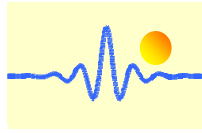

Relation between Input and Output:

Sensor CYCT03-32WS3-1.0-U10mA		Sensor CYCT03-32WS3-1.0-B10mA	
Input current (mA)	Output voltage (V)	Input current (mA)	Output voltage (V)
0	0	-10	0
2.5	1.25	-5	1.25
5	2.5	0	2.5
7.5	3.75	5	3.75
10	5	10	5

Wiring of Terminals for Current Output:

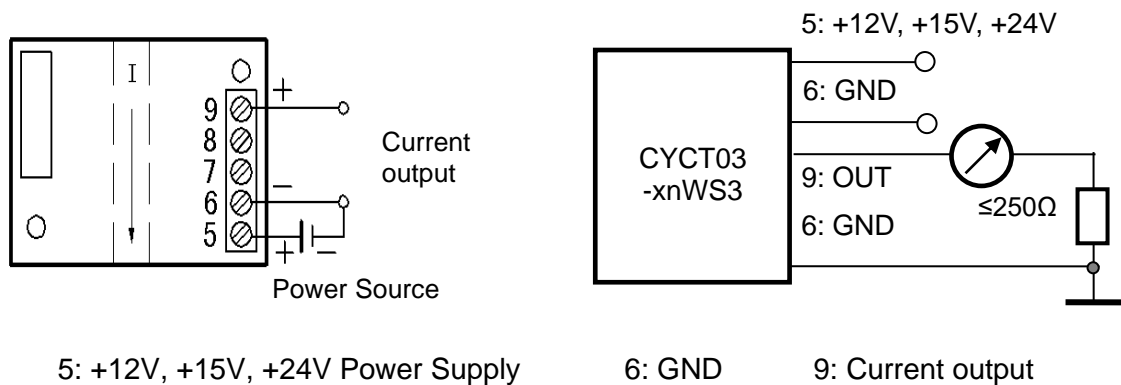

Relation between Input and Output (for $R_m=250 \Omega$):

Sensor CYCT03-54WS3-1.0-U10A			Sensor CYCT03-54WS3-1.0-B10A		
Input current (A)	Output current I_o (mA)	Output voltage V_o (V)	Input current (A)	Output current I_o (mA)	Output voltage V_o (V)
0	4	1	-10	4	1
2.5	8	2	-5	8	2
5	12	3	0	12	3
7.5	16	4	5	16	4
10	20	5	10	20	5

Notice:

1. Before powering on the device, make sure the polarities of all connections are correct. Avoid wrong connection.
2. The two potentiometers can (only if really necessary) be used to adjust the accuracy of the sensor by using a small screwdriver.
3. Make sure to use a measuring instrument which has a better accuracy than the sensor, when calibrating the sensor.
4. Best accuracy can be achieved if window is completely filled by the current-carrying conductor.
5. Output and power supply need to be grounded on pin 6.